

HELICAL BEVEL GEARBOX (HXB)

FULL MODULARITY, STOCK INVENTORY

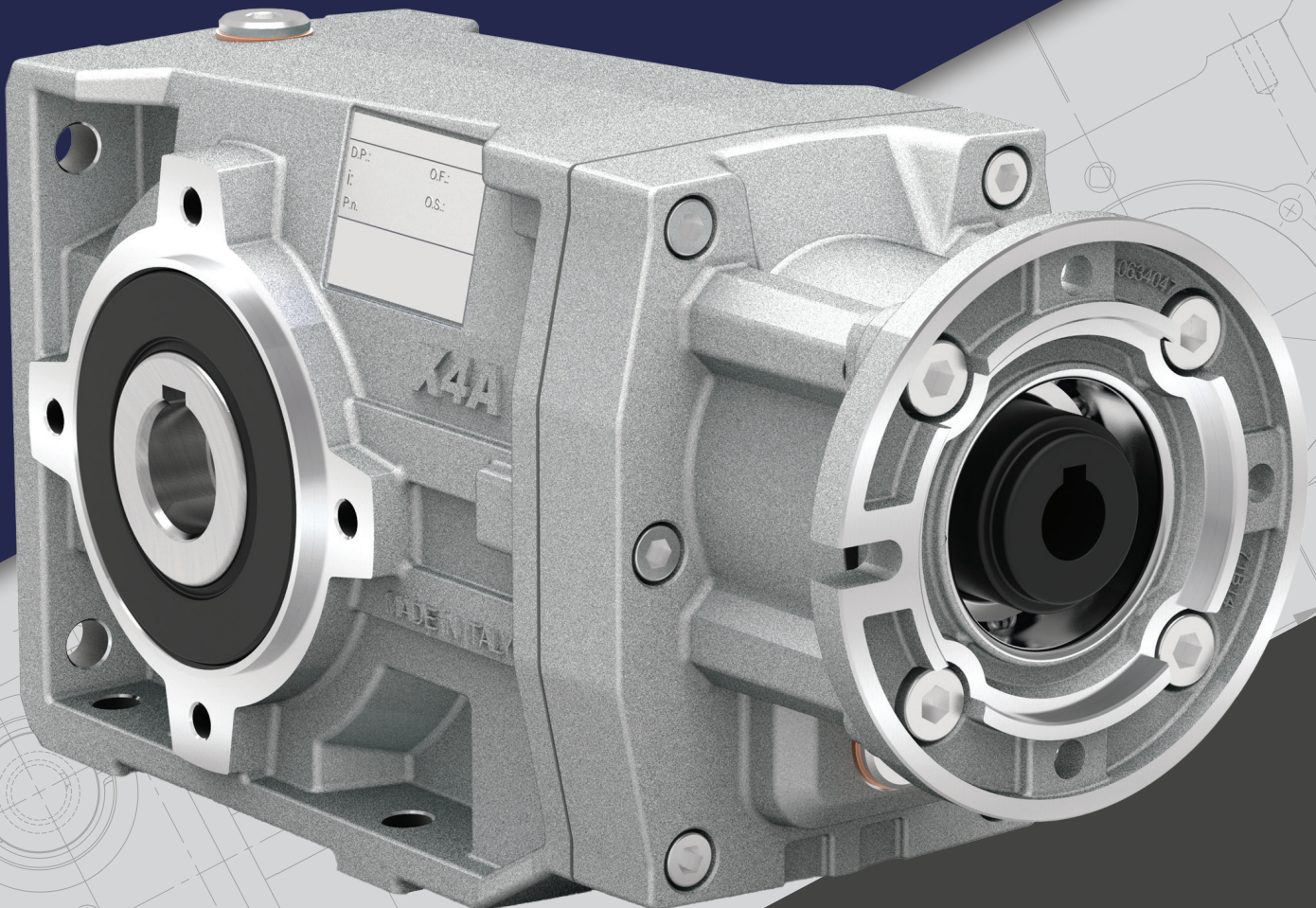

TABLE OF CONTENTS

Helical Inline Gearbox (HXB)	3
HXB Features.....	4
Nomenclature	5
Service Factors	5
X32S 797 (IN-LB) HBX Configurations and Interface Dimensions	
Basic Gearbox, Output Flange, Reaction Arm.....	6
Radial and Axial Loads and Lubrication.....	7
X33S 885 (IN-LB) HBX Configurations and Interface Dimensions	
Basic Gearbox, Output Flange, Reaction Arm.....	8
Radial and Axial Loads and Lubrication.....	9
X42A 1328 (IN-LB) HBX Configurations and Interface Dimensions	
Basic Gearbox, Output Flange, Reaction Arm, Single Output Shaft.....	10
Radial and Axial Loads and Lubrication.....	11
X43A 1416 (IN-LB) HBX Configurations and Interface Dimensions	
Basic Gearbox, Output Flange, Reaction Arm, Single Output Shaft.....	12
Radial and Axial Loads and Lubrication.....	13
X52A 2213 (IN-LB) HBX Configurations and Interface Dimensions	
Basic Gearbox, Output Flange, Reaction Arm.....	14
Radial and Axial Loads and Lubrication.....	15
X53A 2213 (IN-LB) HBX Configurations and Interface Dimensions	
Basic Gearbox, Output Flange, Reaction Arm.....	16
Radial and Axial Loads and Lubrication.....	17
X62A 3629 (IN-LB) HBX Configurations and Interface Dimensions	
Basic Gearbox, Output Flange, Reaction Arm.....	18
Radial and Axial Loads and Lubrication.....	19
X63A 3629 (IN-LB) HBX Configurations and Interface Dimensions	
Basic Gearbox, Output Flange, Reaction Arm.....	20
Radial and Axial Loads and Lubrication.....	21
Ratings	
X32S Ratings Input Speed = 1750 RPM.....	22
X33S Ratings Input Speed = 1750 RPM.....	23
X42A Ratings Input Speed = 1750 RPM	24
X43A Ratings Input Speed = 1750 RPM	25
X52A Ratings Input Speed = 1750 RPM	26
X53A Ratings Input Speed = 1750 RPM	27
X62A Ratings Input Speed = 1750 RPM	28
X63A Ratings Input Speed = 1750 RPM	29
Warnings and Cautions.....	30

HELICAL BEVEL GEARBOX (HXB)

Modular, compact and efficient drive system designed for a variety of applications. Winsmith Helical Bevel Gearbox (HXB) Units are built to order with available stock inventory including available accessories which allow for quick shipment within 1-3 days from our Asheville, NC gearing facility.

- Precision ground and hardened gears to provide optimal durability and efficiency, ensuring long operating life, low noise and minimal energy losses.
- Single-piece aluminum housing design provides excellent corrosion protection and leak free operation. While it does not require a secondary finish, it easily accommodates paint for aesthetic purposes.
- Precision machining guarantees the proper alignment of bearings and gears, which is crucial for optimal operation and reliability.
- Featuring a removable inspection cover that facilitates regular gear inspections during maintenance, ensuring optimal performance over time.
- Fully modular design with input motor C Flange and input shaft for NEMA standard motors.
- Shipped with food grade synthetic oil (Mobil SHC Cibus 320).
- Standard options and accessories to accommodate a variety of mounting configurations.

MODULAR BASE

SIZE	TORQUE (lbf-in)	Ø BORE SIZE OUTPUT SHAFT (in)
2 Stage		
X32S	797	0.750
X42A	1328	1.000
X52A	2213	1.250
X62A	3629	1.375
3 Stage		
X33S	885	0.750
Z43A	1416	1.000
X53A	2213	1.250
X63A	3629	1.375

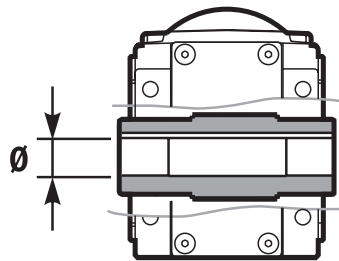

AVAILABLE ACCESSORIES



OUTPUT FLANGE

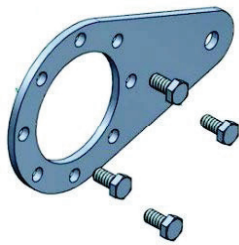

REACTION (TORQUE) ARM

See full list of product Warnings and Cautions on page 30.

HXB FEATURES

Removable Inspection Cover

- Allows periodic inspection of gearing during routine maintenance

Alloy Housing

- Is vacuum impregnated (MIL-STD 276) for protection and sealing. No secondary finish required but readily accepts paint

Oil Seals

- Two oil seals on request

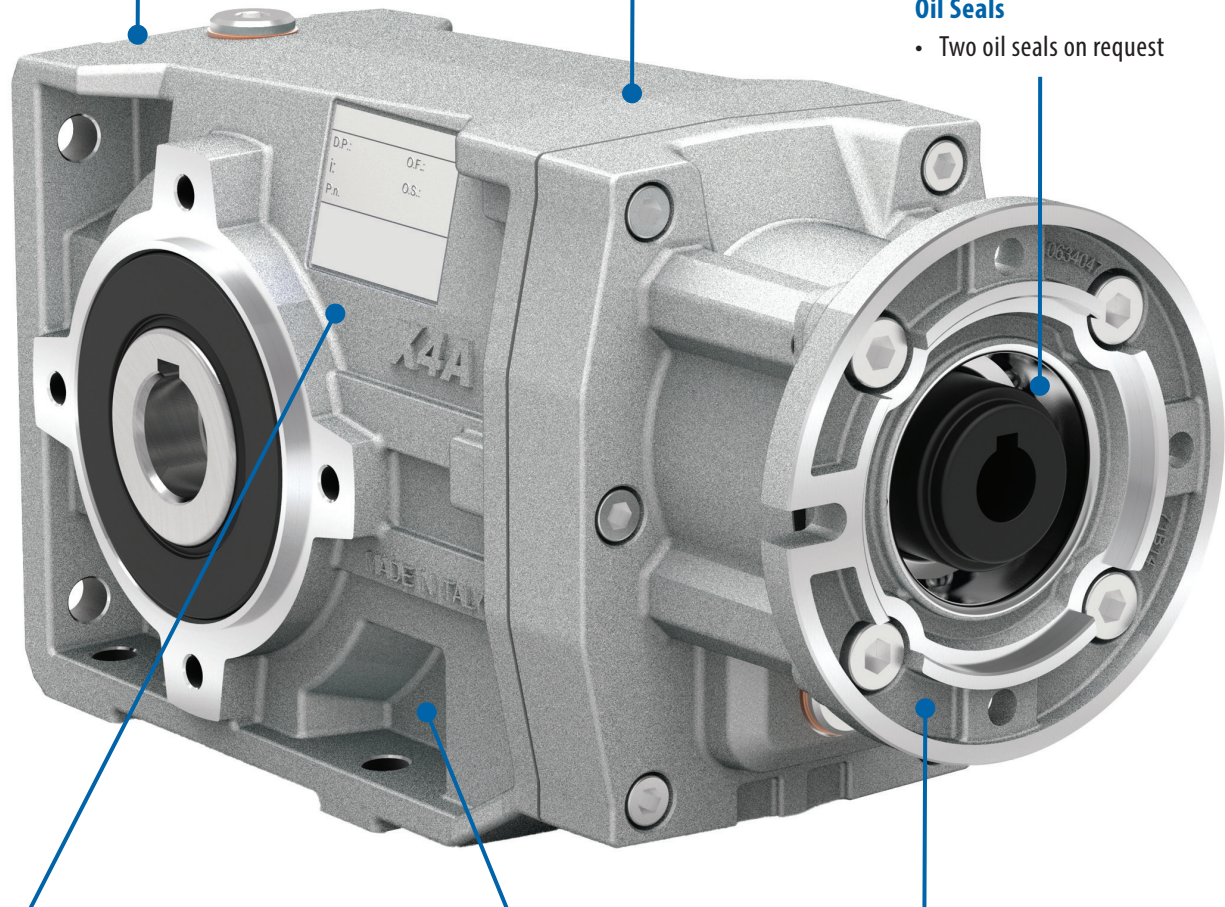

Gears

- Hardened and ground gears

Single-Piece Aluminum

- Combines light weight with high tensile strength. Precision machined for alignment of bearings and gearing

Flange

- Fully modular to IEC and Compact integrated motor. NEMA C flange

NOMENCLATURE

PX32SC02UBBRN-WB3STL

P	X32S	C	02	UB	BR	N	-W	B3	ST	L
----------	-------------	----------	-----------	-----------	-----------	----------	-----------	-----------	-----------	----------

TYPE
P with Motor Flange

SIZE	TORQUE (LB-IN)
2 Stage	
X32S	797
X42A	1328
X52A	2213
X62A	3629
3 Stage	
X33S	885
X43A	1416
X53A	2213
X63A	3629

OUTPUT
C = Hollow Output Shaft

OUTPUT SHAFT DIAMETER (IN)

Standard
X32S/X33S
UB = ø0.750
X42S/X43A
UD = ø1.000
X52S/X53A
UF = ø1.250
X62S/X63A
UG = ø1.375

STANDARD MOUNTING

FB = Standard

BR = Reaction (Torque) Arm

-F = Output Flange

OUTPUT FLANGE (IN)

N = Without Flange

X32S/X33S
1 = ø4.724
X42A, X43A
2 = ø6.299
X52A, X53A, X62A, X63A
3 = ø7.874

INPUT SIZE (IN)

-W = 56C
-X = 143/5TC
-Y = 182/4TC
Flange

MOUNTING POSITION

B3 = Worm Top
B6 = DL Drive Left
B7 = DR Drive Right
B8 = Worm Bottom
V5 = Worm Up (input up)
V6 = Worm Down (input down)
V8 = Worm Incline

INPUT BORE (IN)

ST = Standard

Coupling

-W = ø0.625
-X = ø0.875
-Y = ø1.125

ASSEMBLY OF ACCESSORIES

Flange or Torque Arm
L = Assy Left
R = Assy Right

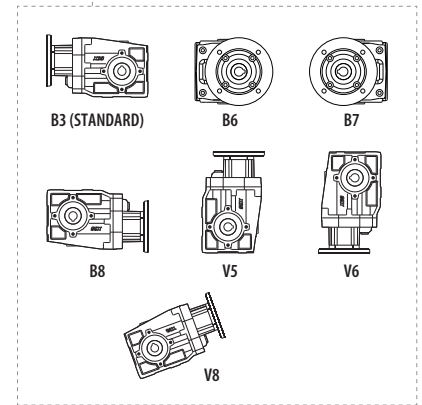

HXB	RATIO								HXB	RATIO							
	X32S	X33S	X42A	X43A	X52A	X53A	X62A	X63A		X32S	X33S	X42A	X43A	X52A	X53A	X62A	X63A
1	7.33		7.29	50.35	6.03	56.76	6.03	56.76	11	32.97	95.65	32.88	150.18	37.57	178.96	37.57	178.96
2	11.22	36.17	11.2	55.22	9.26	65.79	9.26	65.79	12	38.37	101.23	38.12	177.3	48.68	193.36	48.68	193.36
3	13.26	44.21	13.18	59.92	11.36	77.23	11.36	77.23	13	45	127.37	44.89	210.42	54.33	216.84	54.33	216.84
4	15.37	50.68	15.27	65.72	15.36	87.23	15.36	87.23	14	50.67	151.16	50.34	230.79	74.81	252.36	74.81	252.36
5	18.04	55.36	17.93	71.78	17.46	92.18	17.46	92.18	15	58.73	178.46	58.58	272.47		290.67		290.67
6	20.3	60.31	20.25	79.44	19.97	100.47	19.97	100.47	16		211.79		323.37		333.23		333.23
7	2.54	65.88	21.4	92.08	23.6	116.45	23.6	116.45	17		231.37				383.82		383.82
8	23.53	72.25	23.47	95.03	24.45	125.82	24.45	125.82	18		273.16				446.7		446.7
9	27.62	79.64	27.55	126.55	30.69	141.66	30.69	141.66	19		324.18				589.85		589.85
10	29.4	92.31	29.21	133.15	35.35	163.16	35.35	163.16									

SERVICE FACTOR (S.F.) ASSOCIATED WITH FREQUENCY OF START AND HOURS OF OPERATION

TYPE OF LOAD AND STARTS PER HOUR		HOURS OF OPERATION PER DAY			
		3	10	24	
Continuous or intermittent application with starts / hour	≤ 10	Uniform	0.80	1.00	1.25
		Moderate	1.00	1.25	1.50
		Heavy	1.25	1.50	1.75
Intermittent application with starts / hour	> 10	Uniform	1.00	1.25	1.50
		Moderate	1.25	1.50	1.75
		Heavy	1.50	1.75	2.15

PX32SC Basic Gearbox

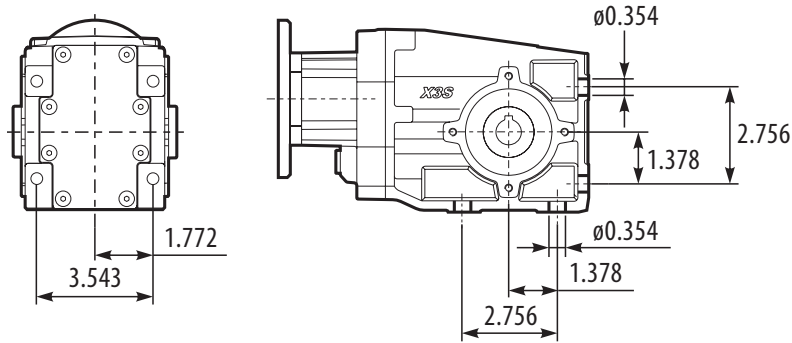
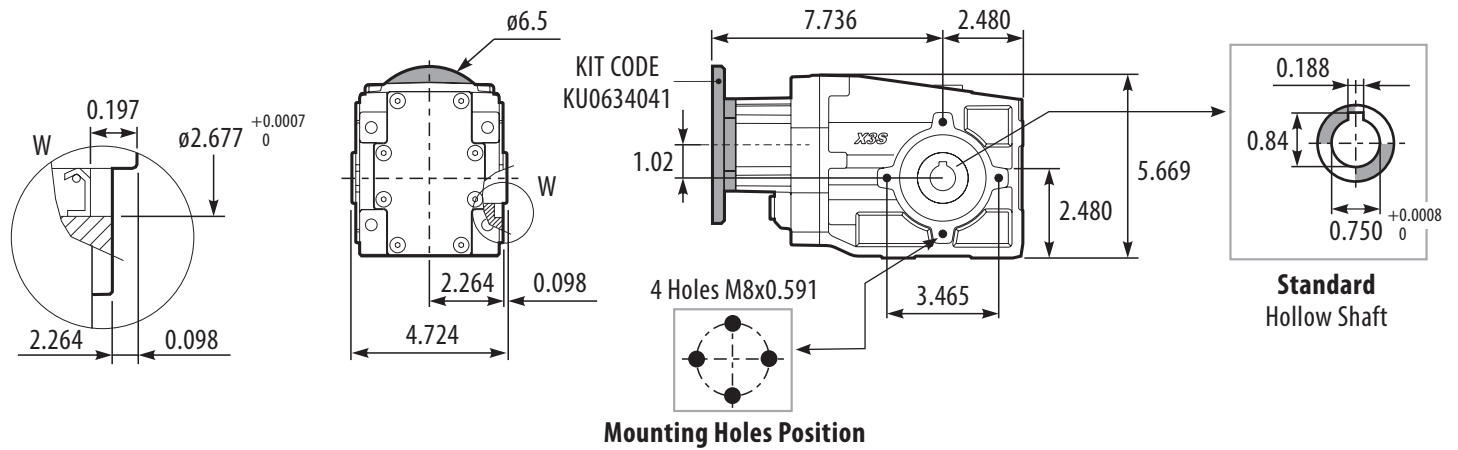

PX32S-F1 Output Flange

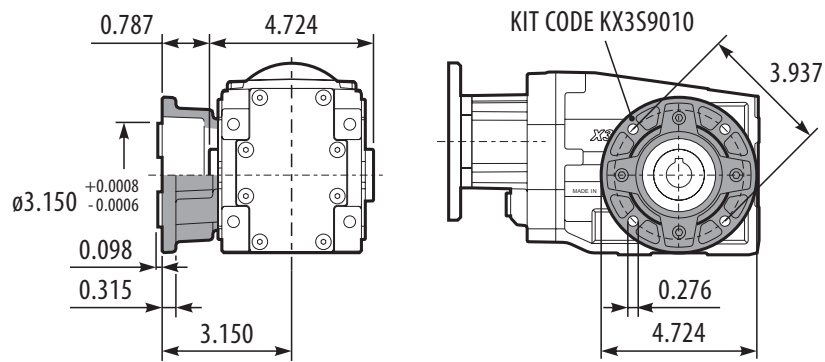

PX32SBR Reaction Arm

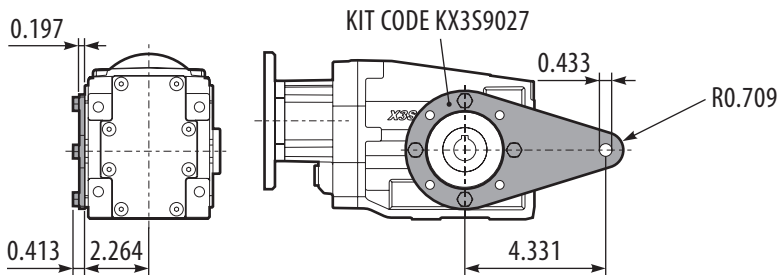

RADIAL AND AXIAL LOADS

Output Shaft

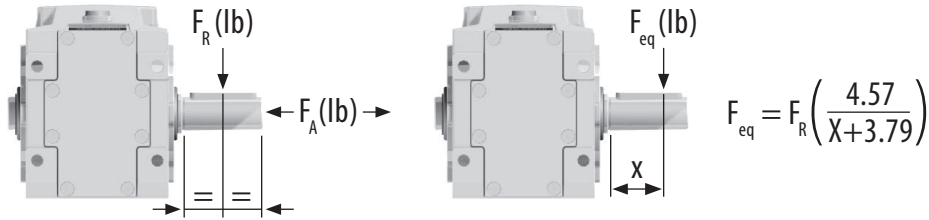

RPM	F _A (lb)	F _R (lb)	RPM	F _A (lb)	F _R (lb)	RPM	F _A (lb)	F _R (lb)
250	90	450	75	126	629	15	126	629
150	101	506	50	126	629			
100	112	562	25	126	629			

F_R On request taper roller bearings to increase radial loads.

Input Shaft

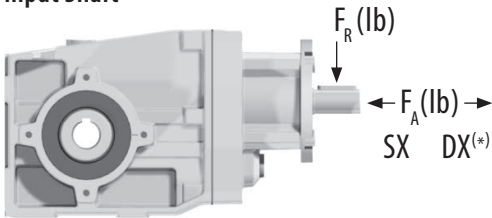

RPM	F _A (lb)	F _R (lb)
1750	54	270
1140	63	315

**High axial loads in the SX and DX directions should be avoided.*

LUBRICATION

STANDARD SUPPLIED	FOR THESE MOUNTING POSITIONS SPECIFY IN THE ORDER OR ADD OIL (oz)					
	B3	B6	B7	B8	V5	V6
14	21	14	21	30	21	Contact Winsmith

PX33SC Basic Gearbox

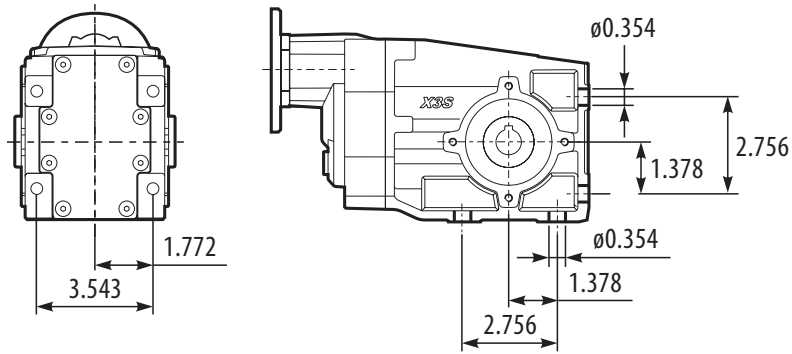
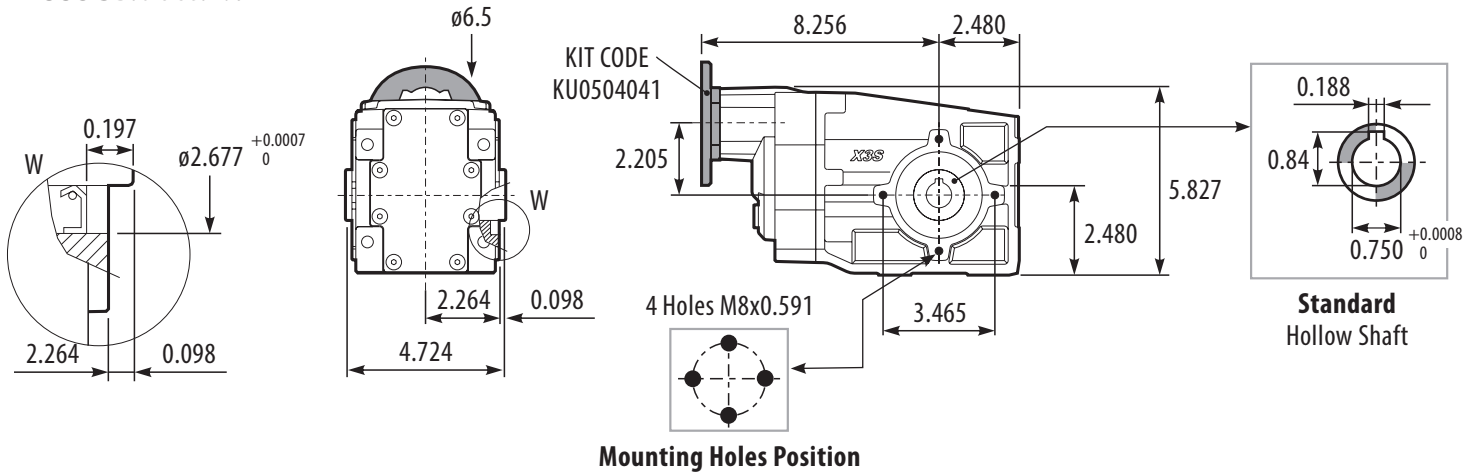

PX33S-F1 Output Flange

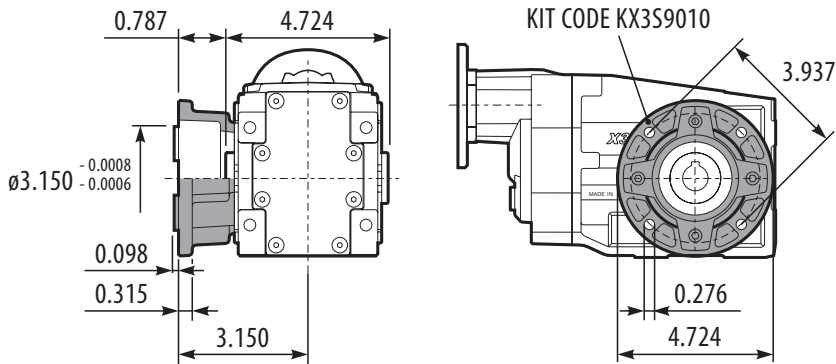

PX33SBR Reaction Arm

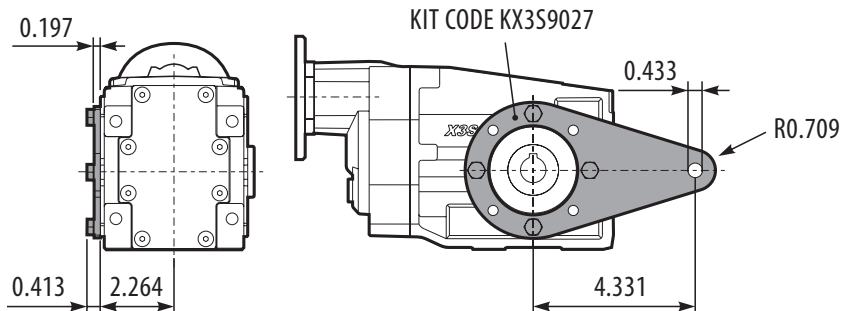

RADIAL AND AXIAL LOADS

Output Shaft

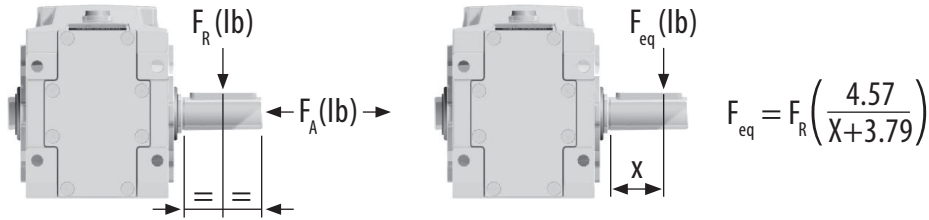

RPM	F _A (lb)	F _R (lb)	RPM	F _A (lb)	F _R (lb)	RPM	F _A (lb)	F _R (lb)
250	90	450	75	126	629	15	126	629
150	101	506	50	126	629			
100	112	562	25	126	629			

F_R On request taper roller bearings to increase radial loads.

Input Shaft

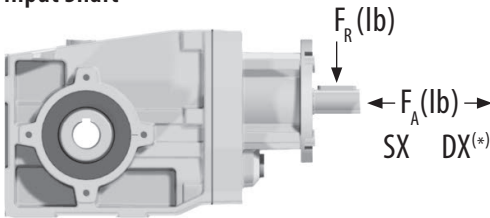

RPM	F _A (lb)	F _R (lb)
1750	31	157
1140	36	180

**High axial loads in the SX and DX directions should be avoided.*

LUBRICATION

STANDARD SUPPLIED	FOR THESE MOUNTING POSITIONS SPECIFY IN THE ORDER OR ADD OIL (oz)					
	B3	B6	B7	B8	V5	V6
25	23	14	23	33	23	Contact Winsmith

RADIAL AND AXIAL LOADS

Output Shaft

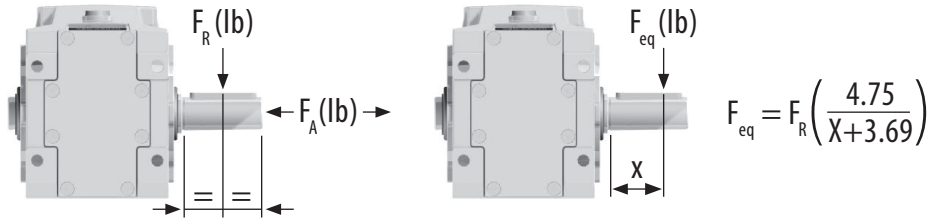

RPM	F _A (lb)	F _R (lb)	RPM	F _A (lb)	F _R (lb)	RPM	F _A (lb)	F _R (lb)
250	112	562	75	180	899	15	216	1079
150	135	674	50	216	1079			
100	157	789	25	216	1079			

F_R On request taper roller bearings to increase radial loads.

Input Shaft

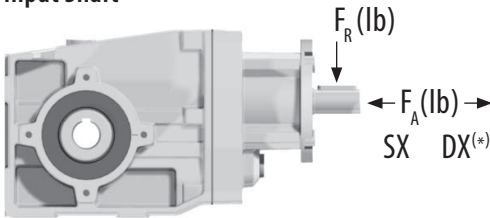

RPM	F _A (lb)	F _R (lb)
1750	54	270
1140	63	315

**High axial loads in the SX and DX directions should be avoided.*

LUBRICATION

STANDARD SUPPLIED	FOR THESE MOUNTING POSITIONS SPECIFY IN THE ORDER OR ADD OIL (oz)					
	B3	B6	B7	B8	V5	V6
21	26	18	25	39	21	Contact Winsmith

PX43AC Basic Gearbox

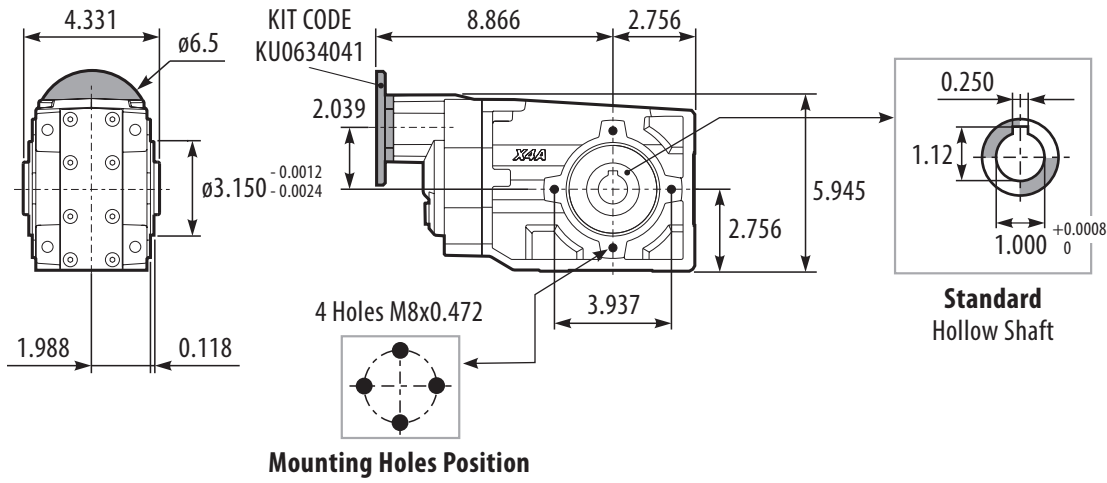

PX43A-F2 Output Flange

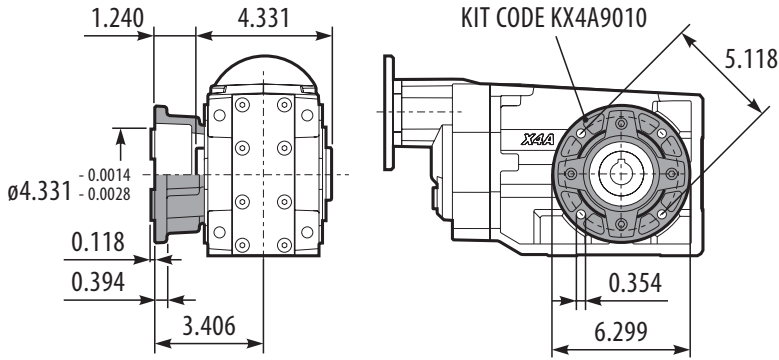

PX43ABR Reaction Arm

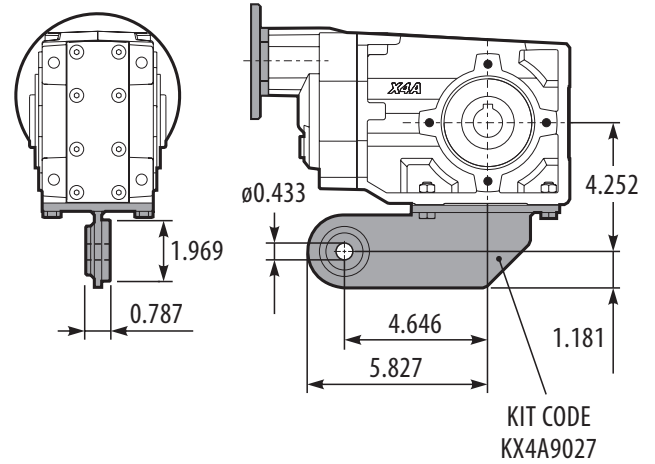

PX43A-A Single Output Shaft

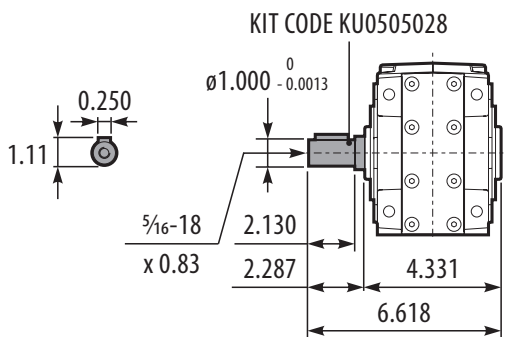

RADIAL AND AXIAL LOADS

Output Shaft

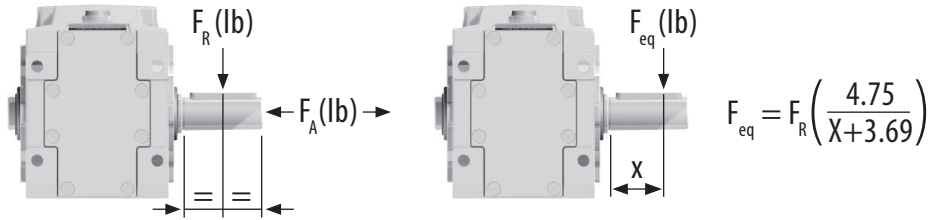

RPM	F_A (lb)	F_R (lb)	RPM	F_A (lb)	F_R (lb)	RPM	F_A (lb)	F_R (lb)
250	112	562	75	180	899	15	216	1079
150	135	674	50	216	1079			
100	157	789	25	216	1079			

F_R On request taper roller bearings to increase radial loads.

Input Shaft

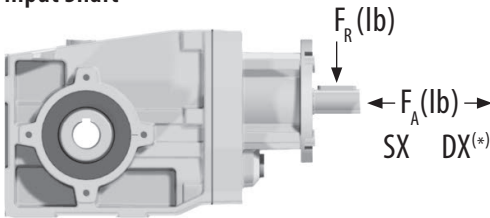

RPM	F_A (lb)	F_R (lb)
1750	31	157
1140	36	180

*High axial loads in the SX and DX directions should be avoided.

LUBRICATION

STANDARD SUPPLIED	FOR THESE MOUNTING POSITIONS SPECIFY IN THE ORDER OR ADD OIL (oz)					
B3	B6	B7	B8	V5	V6	V8
28	28	21	28	42	25	Contact Winsmith

PX52AC Basic Gearbox

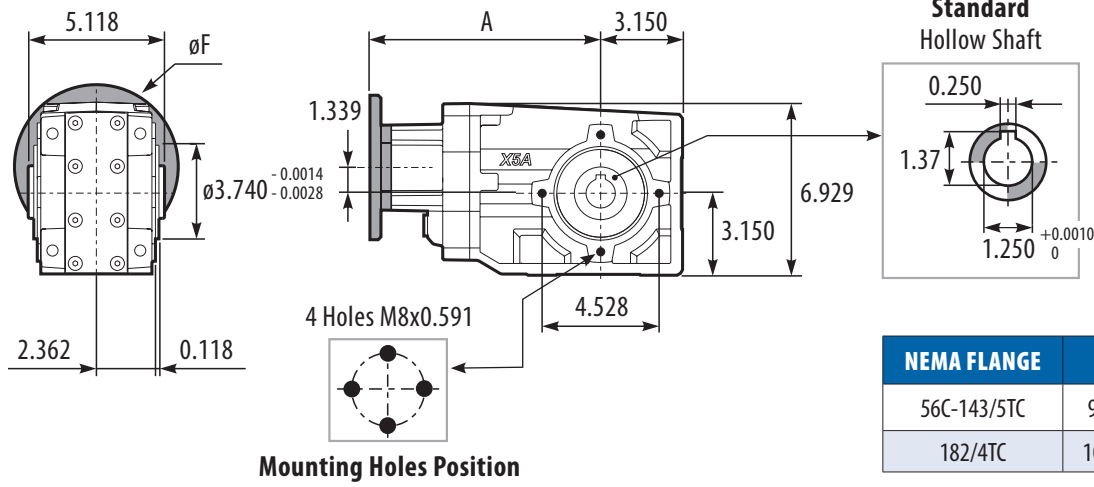

PX52A-F3 Output Flange

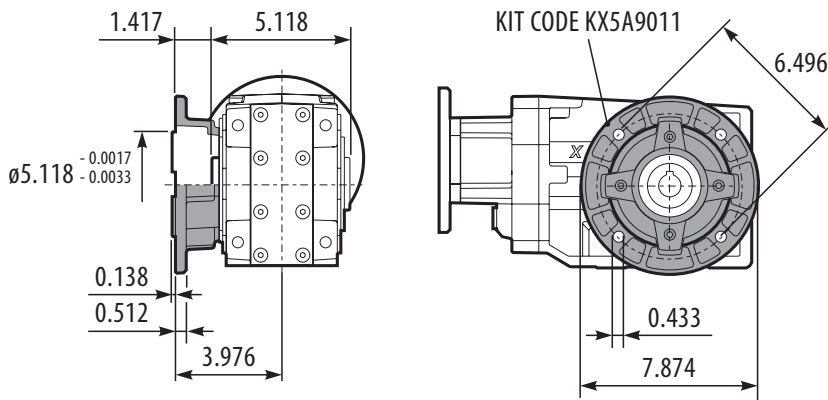

PX52ABR Reaction Arm

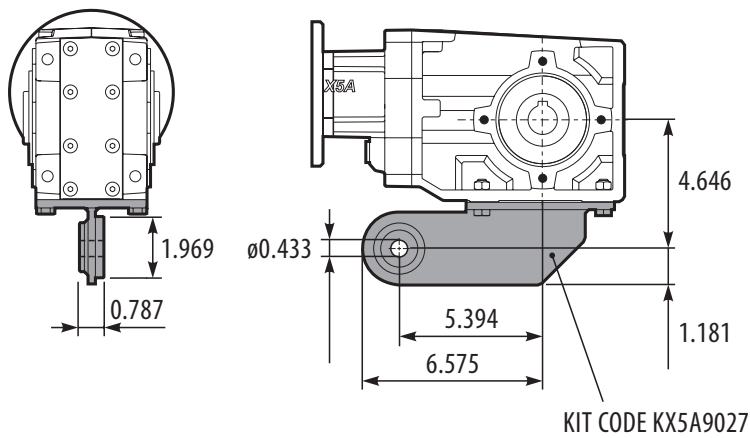

RADIAL AND AXIAL LOADS

Output Shaft

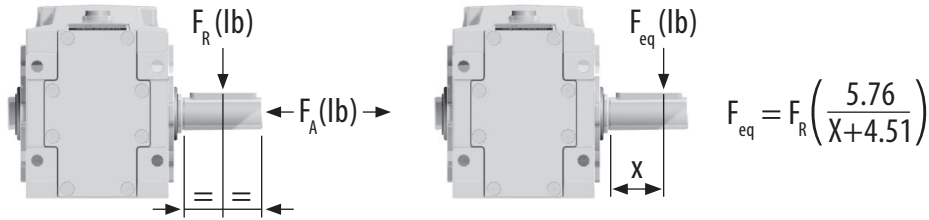

RPM	F _A (lb)	F _R (lb)	RPM	F _A (lb)	F _R (lb)	RPM	F _A (lb)	F _R (lb)
250	135	674	75	184	921	15	373	1866
150	157	787	50	216	1079			
100	180	899	25	303	1517			

F_R On request taper roller bearings to increase radial loads.

Input Shaft

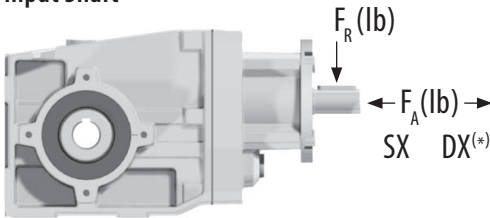

RPM	F _A (lb)	F _R (lb)
1750	101	506
1140	112	562

**High axial loads in the SX and DX directions should be avoided.*

LUBRICATION

STANDARD SUPPLIED	FOR THESE MOUNTING POSITIONS SPECIFY IN THE ORDER OR ADD OIL (oz)					
B3	B6	B7	B8	V5	V6	V8
32	53	26	49	69	40	Contact Winsmith

RADIAL AND AXIAL LOADS

Output Shaft

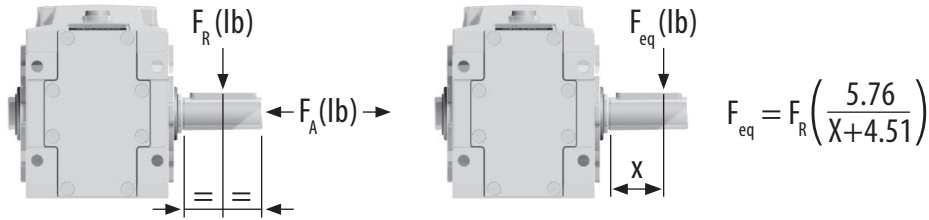

RPM	F_A (lb)	F_R (lb)	RPM	F_A (lb)	F_R (lb)	RPM	F_A (lb)	F_R (lb)
250	135	674	75	184	921	15	373	1866
150	157	787	50	216	1079			
100	180	899	25	303	1517			

F_R On request taper roller bearings to increase radial loads.

Input Shaft

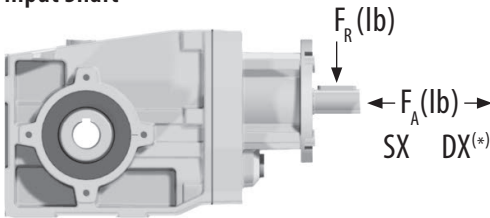

RPM	F_A (lb)	F_R (lb)
1750	90	450
1140	99	495

*High axial loads in the SX and DX directions should be avoided.

LUBRICATION

STANDARD SUPPLIED	FOR THESE MOUNTING POSITIONS SPECIFY IN THE ORDER OR ADD OIL (oz)					
	B3	B6	B7	B8	V5	V6
46	55	30	51	74	44	Contact Winsmith

PX62AC Basic Gearbox

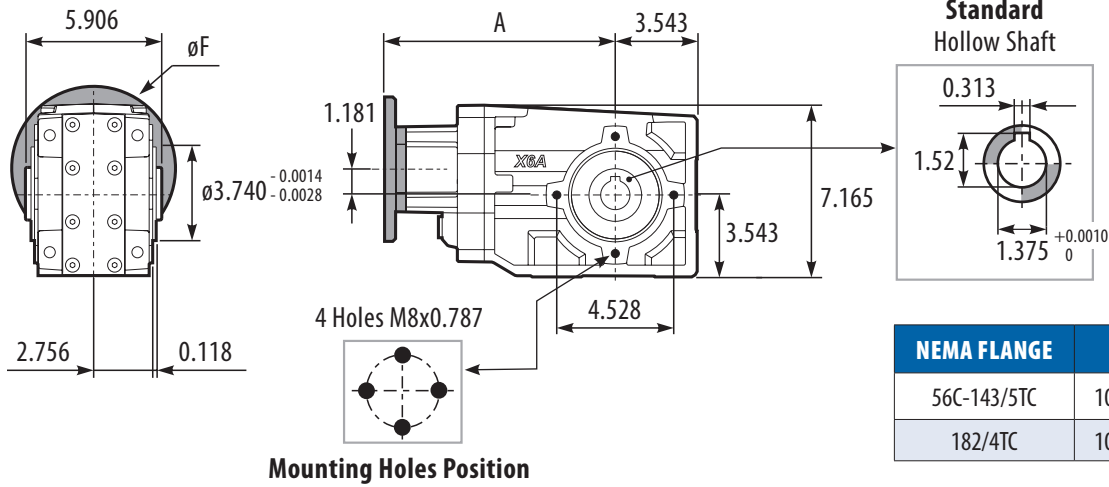

PX62A-F3 Output Flange

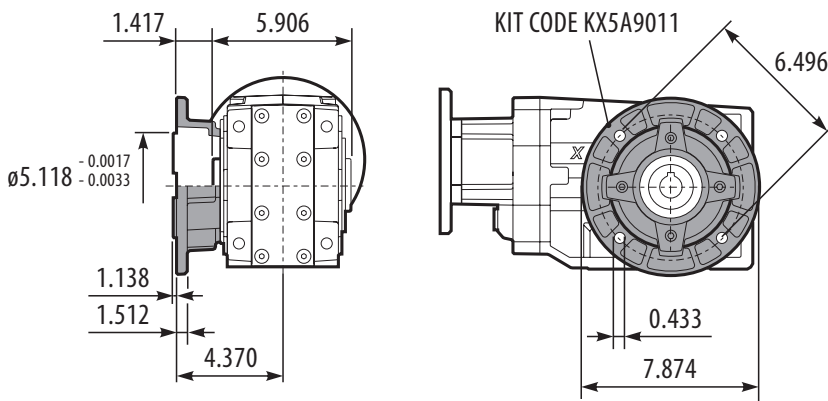

PX62ABR Reaction Arm

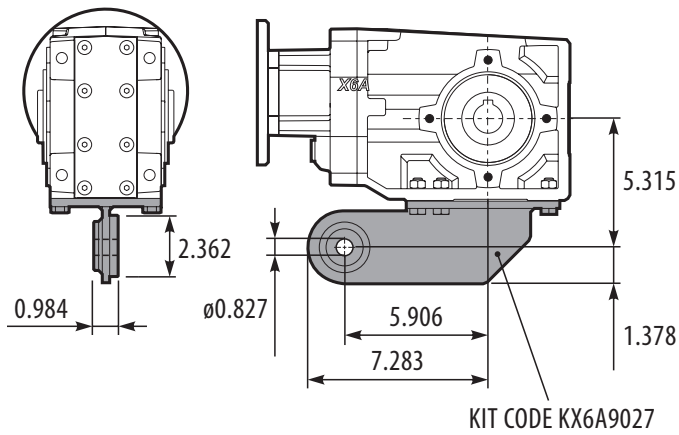

RADIAL AND AXIAL LOADS

Output Shaft

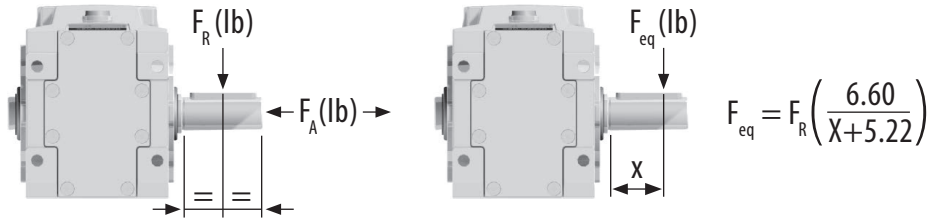

RPM	F _A (lb)	F _R (lb)	RPM	F _A (lb)	F _R (lb)	RPM	F _A (lb)	F _R (lb)
250	135	674	75	200	1000	15	373	1866
150	157	787	50	256	1281			
100	175	877	25	299	1495			

F_R On request taper roller bearings to increase radial loads.

Input Shaft

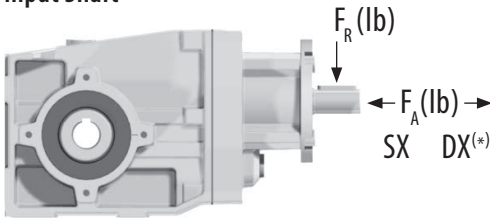

RPM	F _A (lb)	F _R (lb)
1750	101	506
1140	112	562

**High axial loads in the SX and DX directions should be avoided.*

LUBRICATION

STANDARD SUPPLIED	FOR THESE MOUNTING POSITIONS SPECIFY IN THE ORDER OR ADD OIL (oz)					
	B3	B6	B7	B8	V5	V6
44	60	33	56	86	53	Contact Winsmith

PX63AC Basic Gearbox

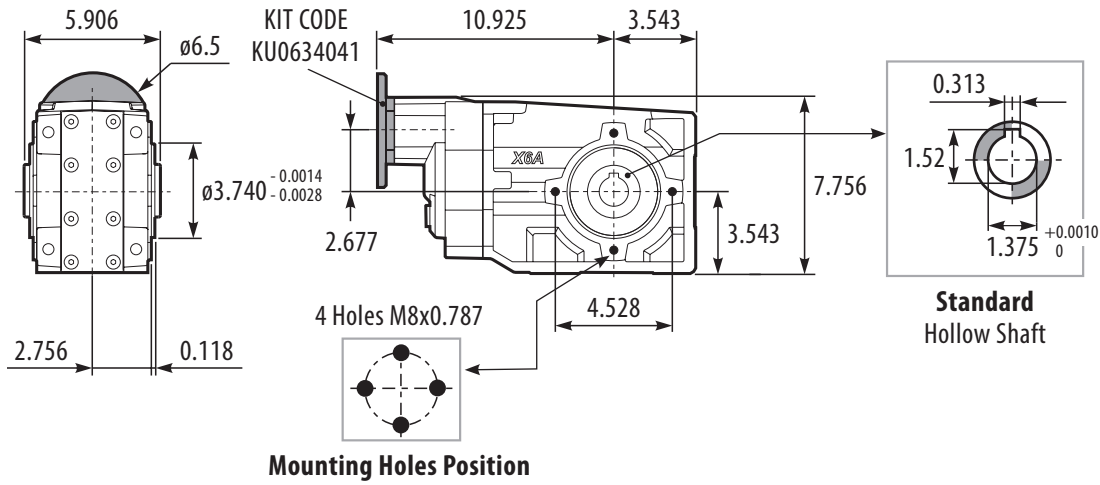

PX63A-F3 Output Flange

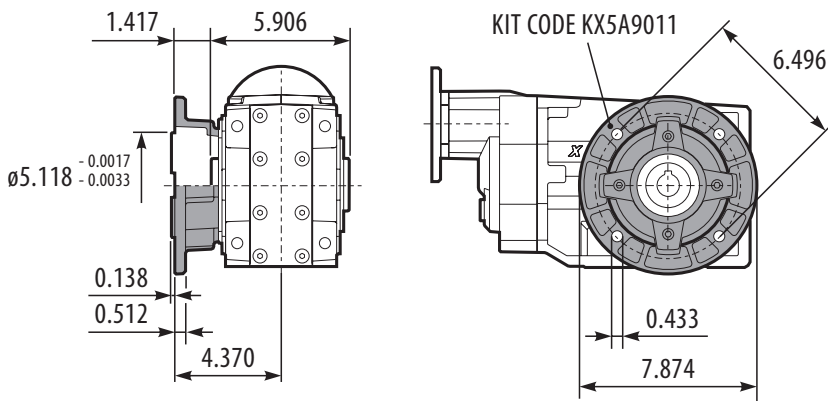

PX63ABR Reaction Arm

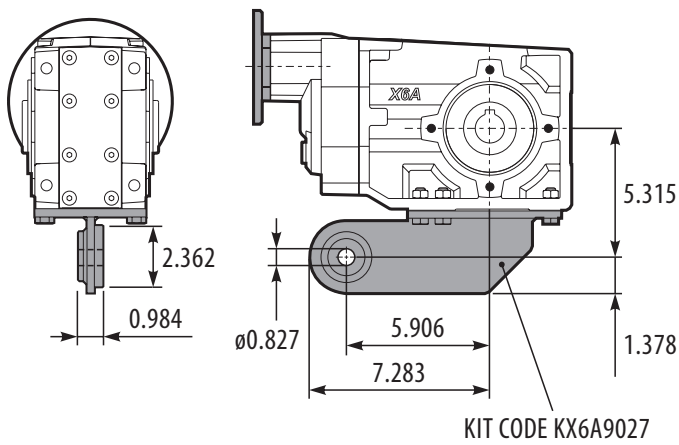

RADIAL AND AXIAL LOADS

Output Shaft

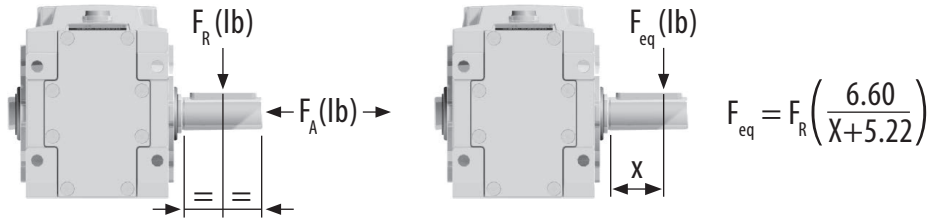

RPM	F _A (lb)	F _R (lb)	RPM	F _A (lb)	F _R (lb)	RPM	F _A (lb)	F _R (lb)
250	135	674	75	200	1000	15	373	1866
150	157	787	50	256	1281			
100	475	877	25	299	1495			

F_R On request taper roller bearings to increase radial loads.

Input Shaft

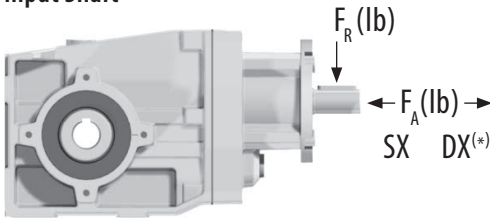

RPM	F _A (lb)	F _R (lb)
1750	90	450
1140	99	495

**High axial loads in the SX and DX directions should be avoided.*

LUBRICATION

STANDARD SUPPLIED	FOR THESE MOUNTING POSITIONS SPECIFY IN THE ORDER OR ADD OIL (oz)					
B3	B6	B7	B8	V5	V6	V8
63	63	37	60	92	58	Contact Winsmith

RATINGS

X32S RATINGS INPUT SPEED = 1750 RPM

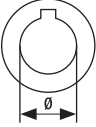
OUTPUT SPEED	RATIO CODE	RATIO	MOTOR POWER	TRANSMITTED OR OUTPUT TORQUE	SERVICE FACTOR	NOMINAL POWER	NOMINAL TORQUE	AVAILABLE NEMA MOTOR FLANGES		OUTPUT SHAFT
								-W 56C	-X 143/5 TC	
RPM		i	HP	(lbf-in)	S.F.	HP	(lbf-in)			Inches
239.0	01	7.33	2.00	507	1.2	2.44	620			 <p>Standard ø0.750</p>
156.0	02	11.22	2.00	776	1.0	1.94	752			
132.0	03	13.26	1.50	688	1.1	1.64	752			
114.0	04	15.37	1.50	797	1.0	1.50	797			
97.0	05	18.04	1.50	936	0.9	1.28	797			
86.0	06	20.30	1.00	702	1.1	1.13	797			
81.0	07	21.54	1.00	745	1.1	1.07	797			
74.0	08	23.53	1.00	814	1.0	0.98	797			
63.0	09	27.62	0.75	716	1.1	0.83	797			
60.0	10	29.40	0.75	762	1.0	0.78	797			
53.0	11	32.97	0.75	855	0.9	0.70	797			
45.6	12	38.37	0.50	663	1.2	0.60	797			
38.9	13	45.00	0.50	778	1.0	0.51	797			
34.5	14	50.67	0.50	876	0.9	0.45	797			
29.8	15	58.73	0.33	670	1.2	0.39	797			
22.6	16	77.55	0.33	885	0.9	0.30	797			

The dynamic efficiency is 0.96 for all ratios

RATINGS

X33S RATINGS INPUT SPEED = 1750 RPM

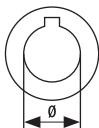
OUTPUT SPEED	RATIO CODE	RATIO	MOTOR POWER	TRANSMITTED OR OUTPUT TORQUE	SERVICE FACTOR	NOMINAL POWER	NOMINAL TORQUE	AVAILABLE NEMA MOTOR FLANGES	OUTPUT SHAFT
RPM		i	HP	(lbf-in)	S.F.	HP	(lbf-in)	-W 56C	Inches
48.40	02	36.17	0.75	918	1.0	0.72	885		 <p>Standard ø0.750</p>
39.60	03	44.21	0.50	748	1.2	0.59	885		
34.50	04	50.68	0.50	858	1.0	0.52	885		
31.60	05	55.36	0.50	937	0.9	0.47	885		
29.00	06	60.31	0.33	674	1.3	0.43	885		
26.60	07	65.88	0.33	736	1.2	0.40	885		
24.20	08	72.25	0.33	807	1.1	0.36	885		
22.00	09	79.64	0.33	890	1.0	0.33	885		
19.00	10	92.31	0.25	781	1.1	0.28	885		
18.30	11	95.65	0.25	810	1.1	0.27	885		
17.30	12	101.23	0.25	857	1.0	0.26	885		
13.70	13	127.37	0.25*	1078	0.8	0.21	885		
11.60	14	151.16	0.25*	1279	0.7	0.17	885		
9.80	15	178.46	0.25*	1511	0.6	0.15	885		
8.30	16	211.79	0.25*	1793	0.5	0.12	885		
7.60	17	231.37	0.25*	1958	0.5	0.11	885		
6.40	18	273.16	0.25*	2312	0.4	0.10	885		
5.40	19	324.18	0.25*	2802	0.3	0.08	885		

The dynamic efficiency is 0.94 for all ratios

*Power is higher than the maximum allowed for this ratio. Select according to the nominal torque required.

RATINGS

X42A RATINGS INPUT SPEED = 1750 RPM

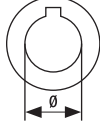
OUTPUT SPEED	RATIO CODE	RATIO	MOTOR POWER	TRANSMITTED OR OUTPUT TORQUE	SERVICE FACTOR	NOMINAL POWER	NOMINAL TORQUE	AVAILABLE NEMA MOTOR FLANGES		OUTPUT SHAFT
								-W 56C	-X 143/5 TC	
RPM		i	HP	(lbf-in)	S.F.	HP	(lbf-in)			Inches
240.00	01	7.29	2.00	504	1.7	3.34	841			 <p>Standard ø1.000</p>
156.00	02	11.20	2.00	774	1.7	3.43	1328			
133.00	03	13.18	2.00	911	1.5	2.91	1328			
115.00	04	15.27	2.00	1056	1.3	2.51	1328			
98.00	05	17.93	2.00	1240	1.1	2.14	1328			
86.00	06	20.25	1.50	1050	1.3	1.90	1328			
82.00	07	21.40	1.50	1110	1.2	1.79	1328			
75.00	08	23.47	1.50	1217	1.1	1.64	1328			
64.00	09	27.55	1.50	1429	0.9	1.39	1328			
60.00	10	29.21	1.00	1010	1.3	1.31	1328			
53.00	11	32.88	1.00	1137	1.2	1.17	1328			
45.90	12	38.12	1.00	1318	1.0	1.01	1328			
39.00	13	44.89	0.75	1164	1.1	0.86	1328			
34.80	14	50.34	0.75	1305	0.9	0.67	1159			
29.90	15	58.58	0.75	1519	0.9	0.66	1328			
22.60	16	77.36	0.50	1337	1.0	0.50	1328			

The dynamic efficiency is 0.96 for all ratios

RATINGS

X43A RATINGS INPUT SPEED = 1750 RPM

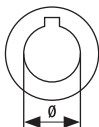
OUTPUT SPEED	RATIO CODE	RATIO	MOTOR POWER	TRANSMITTED OR OUTPUT TORQUE	SERVICE FACTOR	NOMINAL POWER	NOMINAL TORQUE	AVAILABLE NEMA MOTOR FLANGES	OUTPUT SHAFT
RPM		i	HP	(lbf-in)	S.F.	HP	(lbf-in)	-W 56C	Inches
34.80	01	50.35	0.75	1278	1.0	0.78	1328	 <p>Standard ø1.000</p>	
31.70	02	55.22	0.75	1402	0.9	0.71	1328		
29.20	03	59.92	0.75	1521	0.9	0.65	1328		
26.60	04	65.72	0.50	1112	1.2	0.60	1328		
24.40	05	71.78	0.50	1215	1.1	0.55	1328		
22.00	06	79.44	0.50	1345	1.0	0.49	1328		
19.00	07	92.08	0.33	1029	1.3	0.43	1328		
18.40	08	95.03	0.33	1062	1.3	0.41	1328		
13.80	09	126.55	0.33	1414	1.0	0.33	1416		
13.10	10	133.15	0.25	1127	1.3	0.31	1416		
11.70	11	150.18	0.25	1271	1.1	0.28	1416		
9.90	12	177.30	0.25	1501	0.9	0.24	1416		
8.30	13	210.42	0.25*	1781	0.8	0.20	1416		
7.60	14	230.79	0.25*	1953	0.7	0.18	1416		
6.40	15	272.47	0.25*	2306	0.6	0.15	1416		
5.40	16	323.37	0.25*	2737	0.5	0.13	1416		

The dynamic efficiency is 0.94 for all ratios

*Power is higher than the maximum allowed for this ratio. Select according to the nominal torque required.

RATINGS

X52A RATINGS INPUT SPEED = 1750 RPM

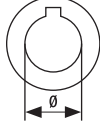
OUTPUT SPEED	RATIO CODE	RATIO	MOTOR POWER	TRANSMITTED OR OUTPUT TORQUE	SERVICE FACTOR	NOMINAL POWER	NOMINAL TORQUE	AVAILABLE NEMA MOTOR FLANGES			OUTPUT SHAFT
								-W 56C	-X 143/5 TC	-Y 182/4TC	
RPM		i	HP	(lbf-in)	S.F.	HP	(lbf-in)				Inches
290.0	01	6.03	5.00	1042	1.1	5.73	1195				 <p>Standard ø1.250</p>
189.0	02	9.26	5.00	1601	0.9	4.28	1372				
154.0	03	11.36	5.00	1964	1.0	5.18	2036				
114.0	04	15.36	3.00	1593	1.4	4.17	2213				
100.0	05	17.46	3.00	1811	1.2	3.67	2213				
88.0	06	19.97	3.00	2072	1.1	3.20	2213				
74.0	07	23.60	3.00	2448	0.9	2.71	2213				
72.0	08	24.45	3.00	2536	0.9	2.62	2213				
57.0	09	30.69	2.00	2122	1.0	2.09	2213				
49.5	10	35.35	1.50	1834	1.2	1.81	2213				
46.6	11	37.57	1.50	1948	1.1	1.70	2213				
35.9	12	48.68	1.00	1683	1.3	1.31	2213				
32.2	13	54.33	1.00	1878	1.2	1.18	2213				
23.4	14	74.81	0.75	1940	1.0	0.72	1859				

The dynamic efficiency is 0.96 for all ratios

RATINGS

X523A RATINGS INPUT SPEED = 1750 RPM

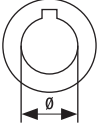
OUTPUT SPEED	RATIO CODE	RATIO	MOTOR POWER	TRANSMITTED OR OUTPUT TORQUE	SERVICE FACTOR	NOMINAL POWER	NOMINAL TORQUE	AVAILABLE NEMA MOTOR FLANGES		OUTPUT SHAFT
								-W 56C	-X 143/5 TC	
RPM		i	HP	(lbf-in)	S.F.	HP	(lbf-in)			Inches
30.8	01	56.76	1.00	1922	1.2	1.15	2213			 <p>Standard ø1.250</p>
26.6	02	65.79	1.00	2227	1.0	0.99	2213			
22.7	03	77.23	0.75	1961	1.1	0.85	2213			
20.1	04	87.23	0.75	2215	1.0	0.75	2213			
19.0	05	92.18	0.75	2341	0.9	0.71	2213			
17.4	06	100.47	0.50	1701	1.3	0.65	2213			
15.0	07	116.45	0.50	1971	1.1	0.56	2213			
13.9	08	125.82	0.50	2130	1.0	0.52	2213			
12.4	09	141.66	0.50	2398	0.9	0.46	2213			
10.7	10	163.16	0.33	1823	1.2	0.40	2213			
9.8	11	178.96	0.33	1999	1.1	0.37	2213			
9.1	12	193.36	0.33	2160	1.0	0.34	2213			
8.1	13	216.84	0.25	1835	1.2	0.30	2213			
6.9	14	252.36	0.25	2136	1.0	0.26	2213			
6.0	15	290.67	0.25	2460	0.9	0.22	2213			
5.3	16	333.23	0.25*	2820	0.8	0.20	2213			
4.6	17	383.82	0.25*	3249	0.7	0.17	2213			
3.9	18	446.70	0.25*	3781	0.6	0.15	2213			
3.0	19	589.85	0.25*	4992	0.4	0.11	2213			

The dynamic efficiency is 0.94 for all ratios

*Power is higher than the maximum allowed for this ratio. Select according to the nominal torque required.

RATINGS

X62A RATINGS INPUT SPEED = 1750 RPM

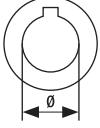
OUTPUT SPEED	RATIO CODE	RATIO	MOTOR POWER	TRANSMITTED OR OUTPUT TORQUE	SERVICE FACTOR	NOMINAL POWER	NOMINAL TORQUE	AVAILABLE NEMA MOTOR FLANGES				OUTPUT SHAFT	
								RPM		i	HP		(lbf-in)
290.0	01	6.03	10.0	2084	1.0	10.19	2124						 <p>Standard ø1.375</p>
189.0	02	9.26	7.5	2402	1.0	7.46	2390						
154.0	03	11.36	7.5	2946	1.1	7.89	3098						
114.0	04	15.36	5.0	2655	1.3	6.42	3408						
100.0	05	17.46	5.0	3018	1.2	5.87	3540						
88.0	06	19.97	5.0	3453	1.1	5.25	3629						
74.0	07	23.6	5.0	4080	0.9	4.45	3629						
72.0	08	24.45	5.0	4226	0.9	4.29	3629						
57.0	09	30.69	3.0	3184	1.1	3.42	3629						
49.5	10	35.35	3.0	3667	1.0	2.97	3629						
46.6	11	37.57	3.0	3897	0.9	2.79	3629						
35.9	12	48.68	2.0	3366	1.0	1.92	3231						
32.2	13	54.33	2.0	3757	1.0	1.93	3629						
23.4	14	74.81	1.0	2587	1.2	1.23	3186						

The dynamic efficiency is 0.96 for all ratios

RATINGS

X63A RATINGS INPUT SPEED = 1750 RPM

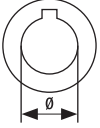
OUTPUT SPEED	RATIO CODE	RATIO	MOTOR POWER	TRANSMITTED OR OUTPUT TORQUE	SERVICE FACTOR	NOMINAL POWER	NOMINAL TORQUE	AVAILABLE NEMA MOTOR FLANGES		OUTPUT SHAFT
								-W 56C	-X 143/5 TC	
RPM		i	HP	(lbf-in)	S.F.	HP	(lbf-in)			Inches
30.8	01	56.76	1.50	2883	1.3	1.89	3629			 Standard ø1.375
26.6	02	65.79	1.50	3341	1.1	1.63	3629			
22.7	03	77.23	1.50	3922	0.9	1.39	3629			
20.1	04	87.23	1.00	2953	1.2	1.23	3629			
19.0	05	92.18	1.00	3121	1.2	1.16	3629			
17.4	06	100.47	1.00	3402	1.1	1.07	3629			
15.0	07	116.45	1.00	3943	0.9	0.92	3629			
13.9	08	125.82	0.75	3195	1.1	0.85	3629			
12.4	09	141.66	0.75	3597	1.0	0.76	3629			
10.7	10	163.16	0.50	2762	1.3	0.66	3629			
9.8	11	178.96	0.50	3030	1.2	0.6	3629			
9.1	12	193.36	0.50	3273	1.1	0.55	3629			
8.1	13	216.84	0.50	3671	1.0	0.49	3629			
6.9	14	252.36	0.33	2819	1.3	0.42	3629			
6.0	15	290.67	0.33	3248	1.1	0.37	3629			
5.3	16	333.23	0.33	3723	1.0	0.32	3629			
4.6	17	383.82	0.25	3249	1.1	0.28	3629			
3.9	18	446.70	0.25	3781	1.0	0.24	3629			
3.0	19	589.85	0.25*	4992	0.7	0.18	3629			

The dynamic efficiency is 0.94 for all ratios

*Power is higher than the maximum allowed for this ratio. Select according to the nominal torque required.

WARNINGS AND CAUTIONS

WARNING

Failure to observe the following warnings could create a risk of death or serious injury.

For safety, Buyer or User should provide protective guards over all shaft extensions and any moving apparatus mounted thereon. The User is responsible for checking all applicable safety codes in their area and providing suitable guards. Failure to do so may result in bodily injury and/or damage to equipment.

Gearboxes operating in high position should have a protective shield for any possible parts falling down for casual accidents where people are moving under them.

Hot oil and reducers can cause severe burns. Use extreme care when removing lubrication plugs and vents.

Use of an oil with an EP additive on units with backstops may prevent proper operation of the backstop. Injury to personnel, damage to the reducer or other equipment may result.

CAUTION:

Failure to observe the following warnings could create a risk of serious injury.

This product is not recommended for use in reducers in man lift or people moving devices.

Make sure that certain applications do not exceed the allowable load capacities published in the current catalog.

Make certain that the power supply is disconnected before attempting to service or remove any components. Lock out the power supply and tag it to prevent unexpected application of power.

Mounting bolts should be routinely checked to ensure that the unit is firmly anchored for proper operation.

NOTES

- Buyer shall be solely responsible for determining the adequacy of the product for all uses to which Buyer shall apply the product. The application by Buyer shall not be subject to any implied warranty of fitness for a particular purpose.
- Reducers are not to be considered fail safe or self-locking devices. If these features are required, a properly sized, independent holding device should be utilized.
- Reducers should not be used as a brake.
- Any brakes that are used in conjunction with a reducer must be sized or positioned in such a way to not subject the reducer to loads beyond the catalog rating.
- Lifting supports including eyebolts are to be used for vertically lifting the gearbox only and no other associated attachments or motors.
- Overhung loads subject shaft bearings and shafts to stress which may cause premature bearing failure and or shaft breakage from bending fatigue, if not sized properly.



WINSMITH
172 EATON STREET
SPRINGVILLE, NY 14141
716-592-9310

© 2025 Winsmith

Winsmith is not responsible for possible errors in catalogues, brochures, websites and other materials, and may change such information without notice. Winsmith reserves the right to modify its products without notice, including products already on order, as long as the modified product meets any agreed-upon specifications.

www.winsmith.com